

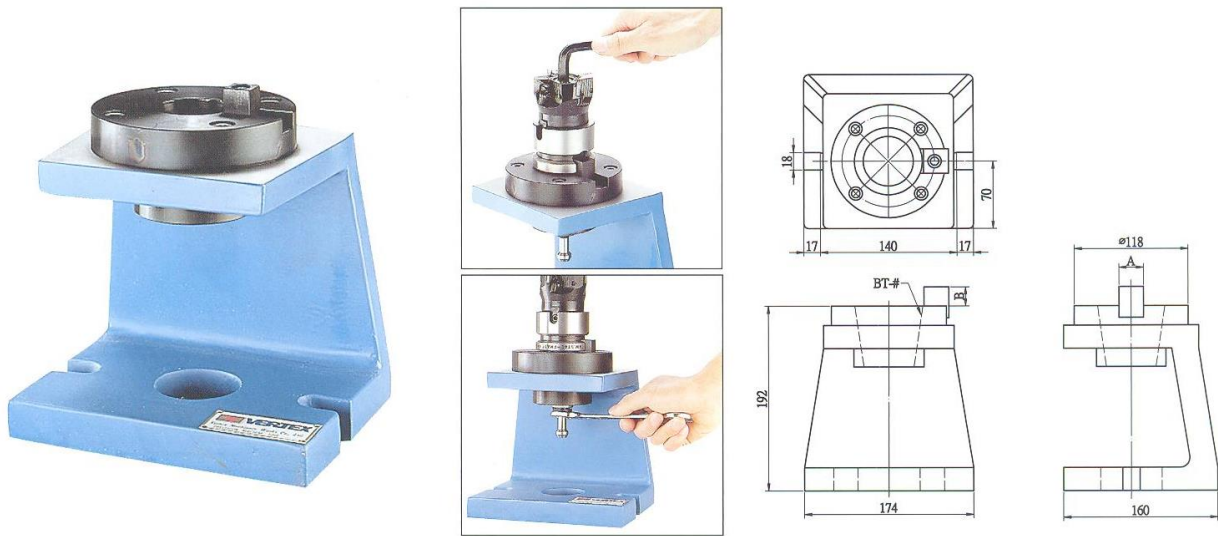

Simple Type Tool Setting Stand



- This tool setting stand is one kind of subsidize tool for helping machine center to work efficiently. To be used fixing the tools on tool holder. It could avoid the method of using draw bar to fix (on machine center). It is safe, and doesn't effect the precision of machine's spindle.
- It is simple structive type. And could fix tooling on the above and hold the pull studs on the below of it. This is the excellent helping tools for simple, rapid and safe.

ORDER NO.	SHANK TAPERS	STD	WEIGHT (kg)	CODE NO.
VTS-BT-30	30	BT ISO NT	11.9	3405-010
VTS-BT-40	40		12.4	3405-011
VTS-BT-50	50		11.9	3405-012
VTS-SK-30	30	CAT DIN 69871A	11.9	3405-013
VTS-SK-40	40		12.4	3405-014
VTS-SK-50	50		11.9	3405-015